



P/N 54-10312

2004 - Up Nissan Titan Stage 2 Magnum Force Cold Air Intake System

17 HP & 27 Ft-lbs of Torque
Max gain @ 3500 RPM

Molded intake tube incorporates factory breather tank for OEM fit and reliability.

Stylish aluminum cover blocks out power robbing engine heat and attenuates sound.

Rugged powder coated housing blocks out power robbing heat and protects the air filter from the elements.

8" inverted top air filter inhales large amounts of air producing maximum horsepower.

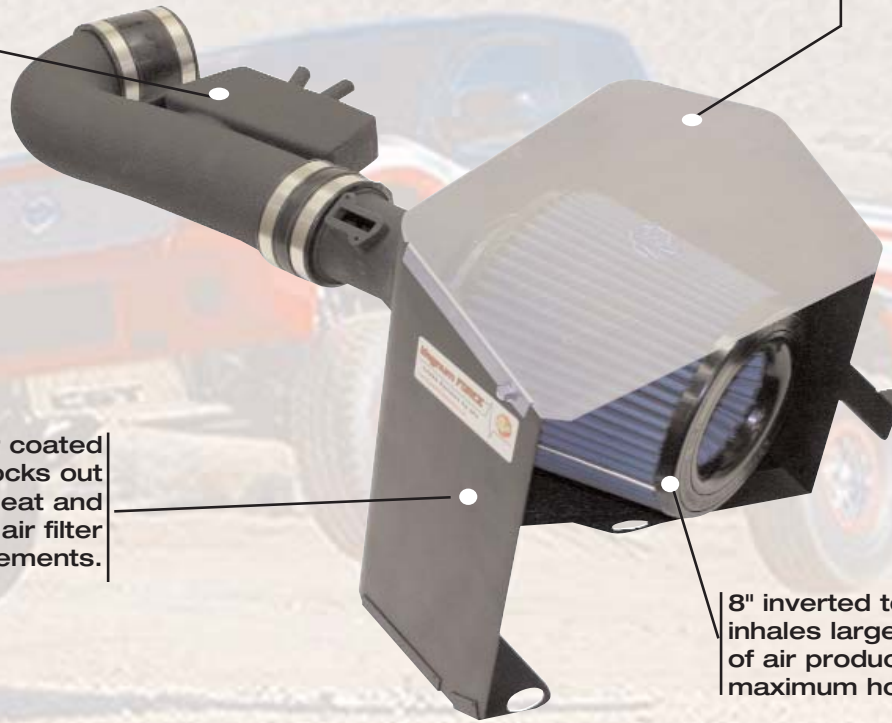

NISSAN

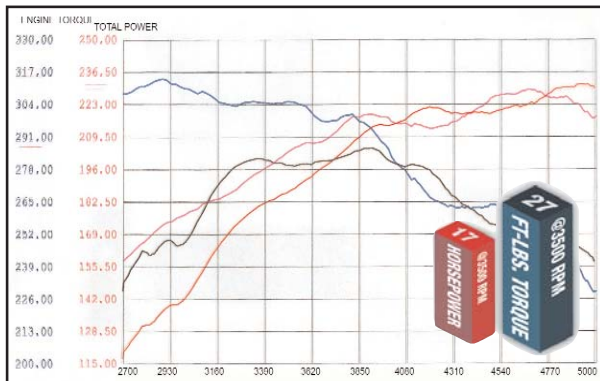

Dyno Results

04-up Nissan Titan V8-5.6 L

| | |
|--------------------|-----------------|
| Part Number | 54-10312 |
| MSRP | \$421.43 |
| Replacement Filter | 24-91034 |
| UPC | 80295950038 |
| Box size | 18" x 16" x 11" |
| Shipping weight | 14 lbs. |



Restore Kits
90-50001 Blue Aerosol
90-50501 Blue Squeeze



advanced FLOW engineering™

191 Granite St. Corona, CA 92879 • 951-493-7100 • FAX 909-498-8705 • www.aFefilters.com

Made in the U.S.A.

All prices are subject to change without notice.

Jun.-2005
40-12081